



TONE RINGER SC9106

GENERAL DESCRIPTION

The SC9106 is a bipolar integrated circuit designed for telephone bell replacement.

FUNCTIONS

- Two oscillators
- Output amplifier
- Power supply control circuit

FEATURES

- Designed for telephone bell replacement.
- Low current drain.
- Small size 'MINIDIP' package.
- Adjustable 2-frequency tone.
- Adjustable warbling rate.
- Built-in hysteresis prevents false triggering and rotary dial 'CHIRPS'.
- Extension tone ringer modules.
- Alarms or other alerting devices.
- Adjustable for reduced supply initiation current. DIP-8

Outline Drawing

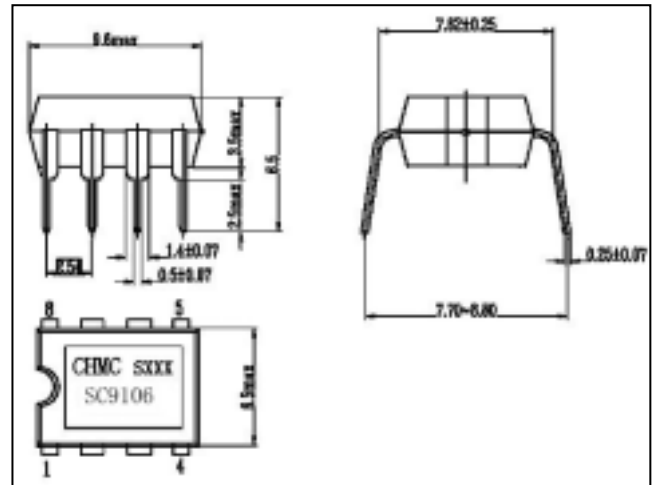

BLOCK DIAGROM

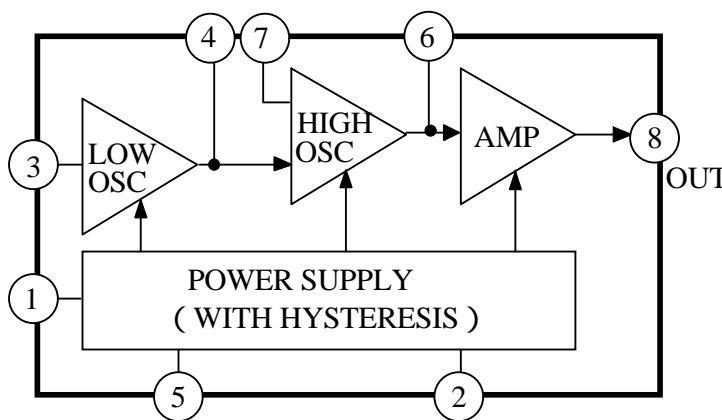

PIN CONNECTION

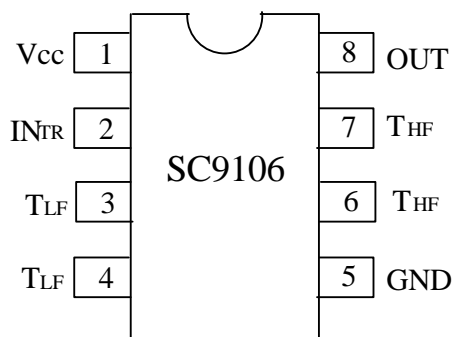

MAXIMUM RATINGS

Characteristics	Symbol	Value	Unit
Supply Voltage	V _{CC}	30	V
Power Dissipation	P _D	400	mW
Operating Temperature	T _{opr}	-45~70	°C
Storage Temperature	T _{stg}	-65~150	°C

ELECTRICAL CHARACTERISTICS (T_a=25°C)

(All voltage referenced to GND unless otherwise specified)

Characteristic	Test condition	Symbol	Min	Typ	Max	Unit
Operating Supply Voltage		V _{CC}			29	V
Initiation Supply Voltage *1	See Fig.2	V _{SI}	17	19	21	V
Initiation Supply Current *1	6.8k-Pin 2 to GND	I _{SI}	1.4	2.5	4.2	mA
Sustaining Voltage *2	See Fig.2	V _{SUS}	9.7	11.0	12	V
Sustaining Current *2	No load V _{CC} =V _{SUS} , see Fig.2	I _{SUS}	0.7	1.4	2.5	mA
Output Voltage High	V _{CC} =21V, I ₈ =-15mA Pin6=6V, Pin7=GND	V _{OH}	17	19	21	V
Output Voltage Low	V _{CC} =21V, I ₈ =15mA Pin7=6V, Pin6=GND	V _{OL}			1.6	V
I _{IN} (Pin 3)	Pin3=6V, Pin4=GND Pin7=6V, Pin6=GND				500	nA
I _{IN} (Pin7)					500	
High Frequency 1	R3=191kΩ, C3=6800pF	f _{H1}	461	512	563	Hz
High Frequency 2	R3=191kΩ, C3=6800pF	f _{H2}	576	640	704	Hz
Low Frequency	R2=165kΩ, C2=0.47μF	f _L	9.0	10	11	Hz

* Note (see electrical characteristics sheet)

1. Initiation supply voltage (V_{SI}) is the supply voltage required to start the tone ringer oscillating
2. sustaining voltage (V_{SUS}) is the supply voltage required to maintain oscillation.

TEST CIRCUIT

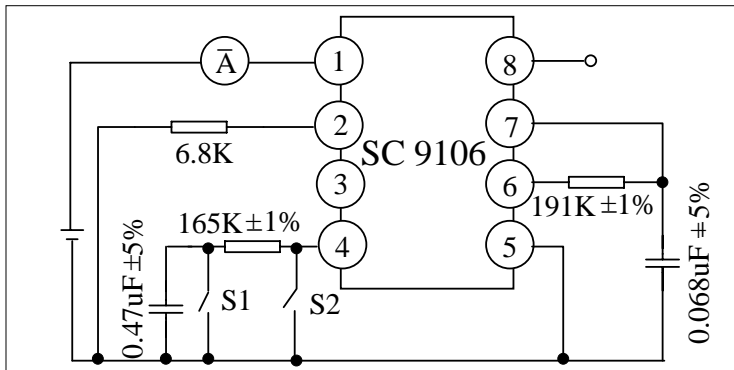

APPLICATION CIRCUIT

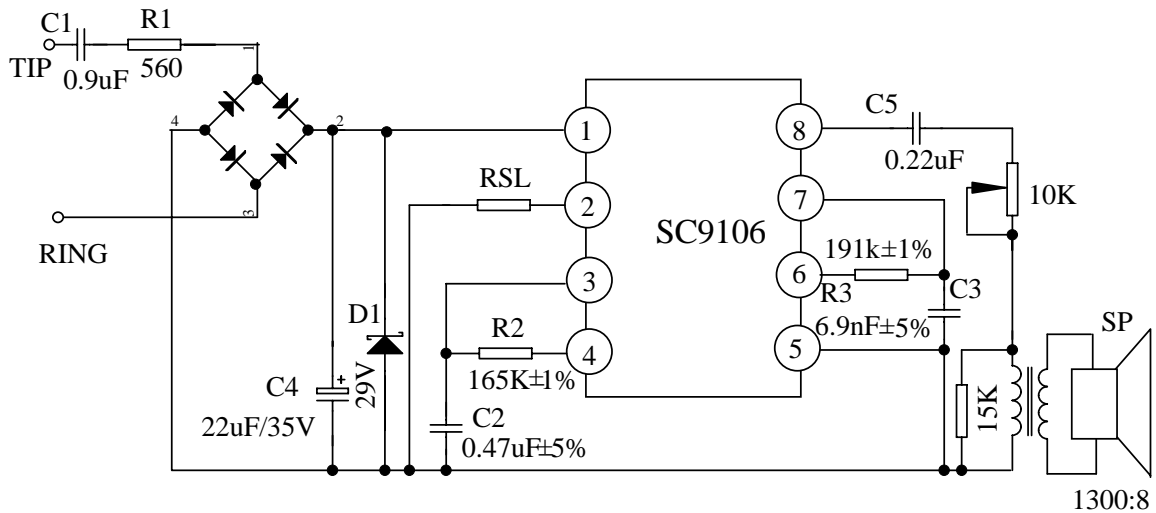

APPLICATION NOTE

The application circuit illustrates the use of the UTC9106 device in typical telephone tone ringer application.

The AC ringer signal voltage appears across the TIP and RING inputs of the circuit and is attenuated by capacitor C1 and resistor R1.

C1 also provides isolation from DC voltage (48V) on the exchanged line.

After full wave rectification by the bridge diode, the waveform is filtered by capacitor C4 to provide a DC supply for the tone ringer chip.

As this voltage exceeds the initiation voltage (V_{si}), oscillation starts.

With the components shown, the output frequency chops between 512Hz (f_{H1}) and 640 Hz (f_{H2}) at 10Hz (f_L) rate.

The loudspeaker load is coupled through a 1300W to 8W transformer.

The output coupling capacitor C5 is required with transformer coupled loads.

When driving a piezo-ceramic transducer type load, the coupling C5 and transformer (1300 Ω :8 Ω) are not required.

However, a current limiting resistor is required.

The low frequency oscillator oscillates at a rate (f_L) controlled by an external resistor (R2) and capacitor (C2).

The frequency can be determined using the relation $f_L=1/1.289 R_2 * C_2$. The high frequency oscillates at a f_{H1} , f_{H2} controlled by an external resistor (R3) and capacitor (C3). The frequency can be determined using the relation $f_{H1}=1/1.504 R_3 * C_3$ and $f_{H2}= 1/1.203 R_3 * C_3$.

Pin 2 of the SC9106 allows connection of external resistor RSL, which is used to program the slope of the supply current vs supply voltage characteristics (see Fig.3), and hence the supply current up to the initiation voltage (V_{si}). This initiation voltage remains constant independent of RSL.

The supply current drawn prior to triggering varies inversely with RSL, decreasing for increasing value of resistance. Thus, increasing the value of RSL, will decrease the amount of AC ringing current required to trigger the device. As such, longer subscriber loops are possible since less voltage is dropped per unit length of loop wire due to the lower current level. RSL can also be used to compensated for smaller AC coupling capacitors (C5 on application circuit) (higher impedance) to the line which can be used to alter the ringer equivalence number of a tone ringer circuit.

The graph in Fig.3 illustrates the variation of supply current with supply voltage of the SC9106.

Three curves are drawn to show the variation of initiation current with RSL. Curve B (RSL=6.8k Ω) shows the I-V characteristic for SC9106 tone ringer. Curve A is a plot with RSL<6.8k Ω and shows an increase in the current drawn up to the initiation voltage V_{si} . The I-V characteristic after initiation remains unchanged. Curve C illustrates the effect of increasing RSL above 6.8kW initiation current decreases but again current after triggering is unchanged.

CHARACTERISTICS CURVES

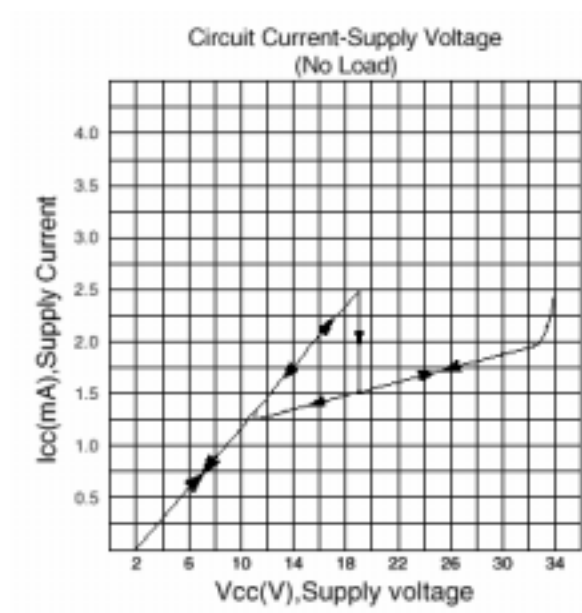

Fig.2

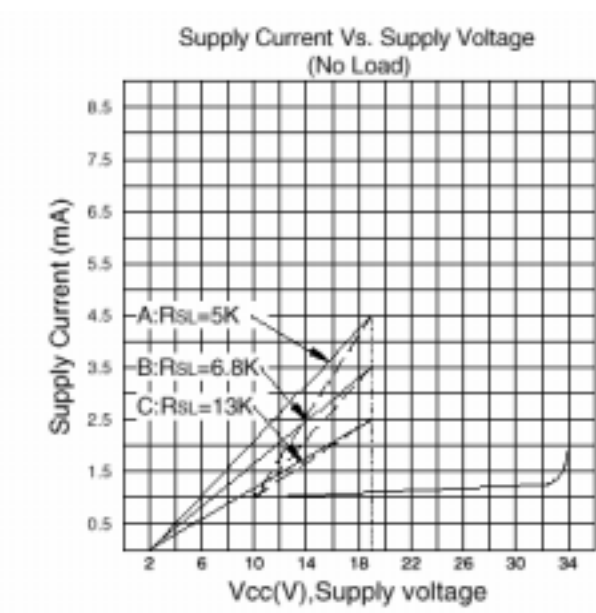

Fig.3